

Fig1

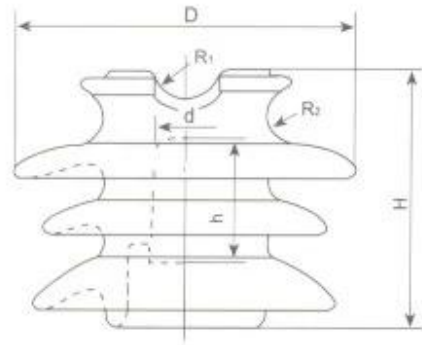

Fig2

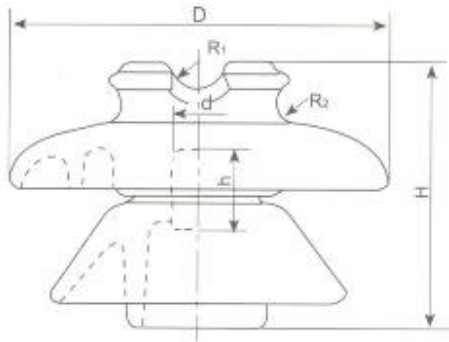

Fig3

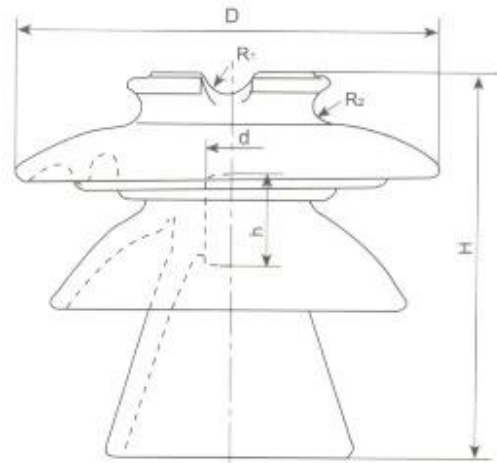

Fig4

**MAIN DIMENSTIONS AND STANDARD PARTICULARS**

Cat.No. Class ANSI	Glaze	Fig. No.	Main dimensions in						Minimum pin Height in	Leakage distance in	Dry arcing distance in
			H	h	D	d	R1	R2			
M10K15 (56-1)	Plain	1/2	5 3/4	2	7 1/2	1 3/8	3/4	9/16	6	13	7
M10K16 (56-1)	Radio freed	1/2	5 3/4	2	7 1/2	1 3/8	3/4	9/16	6	13	7
M10K17 (56-2)	Plain	1/2	6 1/2	2	9	1 3/8	3/4	9/16	7	17	8 1/4
M10K18 (56-2)	Radio freed	1/2	6 1/2	2	9	1 3/8	3/4	9/16	7	17	8 1/4
M10K19 (56-3)	Plain	3	7 1/2	2	10 1/2	1 3/8	3/4	9/16	8	21	9 1/2
M10K20 (56-3)	Radio freed	3	7 1/2	2	10 1/2	1 3/8	3/4	9/16	8	21	9 1/2
M10K21 (56-4)	Plain	3	9 1/2	2	12	1 3/8	3/4	9/16	10	27	11 1/4
M10K22 (56-4)	Radio freed	3	9 1/2	2	12	1 3/8	3/4	9/16	10	27	11 1/4
M10K23 (56-5)	Plain	4	12 1/2	2 1/2	13 1/2	1 3/8	3/4	9/16	12	34	14
M10K24 (56-5)	Radio freed	4	12 1/2	2 1/2	13 1/2	1 3/8	3/4	9/16	12	34	14
M10K25	Plain	1	6 1/2	2	9	1 3/8	3/4	9/16	6	13	7
M10K26	Radio freed	1	6 1/2	2	9	1 3/8	3/4	9/16	6	13	7

Cat.No. Class ANSI	Low frequency voltage kV			Critical-impulse flashover voltage kV		Radio-influence voltage		Cantilever strength lb.	No. used before
	Dry flashover	Wet flashover	Puncture	Positive	Negative	Low frequency test voltage to ground kV	Maximum RIV at 1000kHz µV		
M10K16 (56-1)	95	60	130	150	190	15	100	2500	P1-23-M
M10K17 (56-2)	110	70	145	175	225	22	12000	3000	P2-23-M
M10K18 (56-2)	110	70	145	175	225	22	100	3000	P2-23-M
M10K19 (56-3)	125	80	165	200	265	30	16000	3000	P-35-M
M10K20 (56-3)	125	80	165	200	265	30	200	3000	P-35-M
M10K21 (56-4)	140	95	185	225	310	30	16000	3000	P-46-M
M10K22 (56-4)	140	95	185	225	310	30	200	3000	P-46-M
M10K23 (56-5)	175	125	225	270	340	44	25000	3000	P-69-M
M10K24 (56-5)	175	125	225	270	340	44	200	3000	P-69-M
M10K25	95	60	130	150	190	15	8000	2500	P-23-M
M10K26	95	60	130	150	190	15	100	2500	P-23-M